

TX-F FORCE ONE FRONT FORESTRY MULCHER



**PATENTED
PENDING**



NB: AT THE TIME OF ORDER, PLEASE NOTIFY THE VOLTAGE OF THE ELECTRICAL SYSTEM (12-24 V)

SAME ENDURANCE FOR THE FRONTAL VERSION THANKS TO THE REINFORCED SHELL, VALVE KIT INCLUDED IN STANDARD EQUIPMENT PROTECTS PISTON ENGINE FROM PRESSURE PEAKS. IT'S THE PERFECT TOOL TO CREATE FIREBREAK LINES, OPEN TRACKS, PATHS AND CUT DOWN TREES.

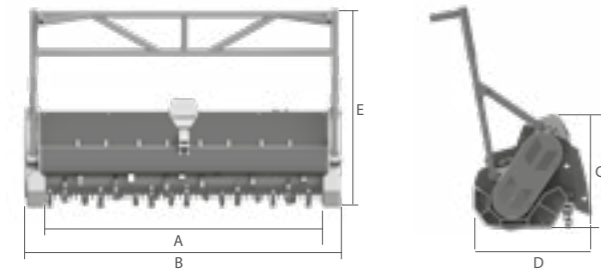

| | MOD. | TX5F-170 | TX5F-195 |
|--------------|-----------------|--------------|-------------|
| A | MM (IN) | 2010 (79,1) | 2260 (88,9) |
| B | MM (IN) | 2010 (79,1) | 2260 (88,9) |
| C | MM (IN) | 750 (29,5) | 750 (29,5) |
| D | MM (IN) | 820 (32,2) | 820 (32,2) |
| E | MM (IN) | 1700 (66,93) | 1950 (516) |
| 5 | KG (LB) | 990 (2183) | 1090 (2403) |
| 6 | KG (LB) | 985 (2171) | 1085 (2392) |
| 7 | KG (LB) | 830 (1830) | 880 (1940) |
| 5 6 7 | MM (IN) | 220 (8,6) | 220 (8,6) |
| 3 | N. | 3 | 3 |
| MIN | L/MIN (GAL/MIN) | 90 (24) | 90 (24) |
| MAX | L/MIN (GAL/MIN) | 300 (79) | 300 (79) |
| MAX | BAR (PSI) | 400 (5801) | 400 (5801) |
| | | STD 14 PIN | STD 14 PIN |

- 5** W/O COUPLER
- 6** W/O COUPLER
- 7** W/O COUPLER
- 5 6 7**
- 3**
- MIN**
- MAX**
- MAX**

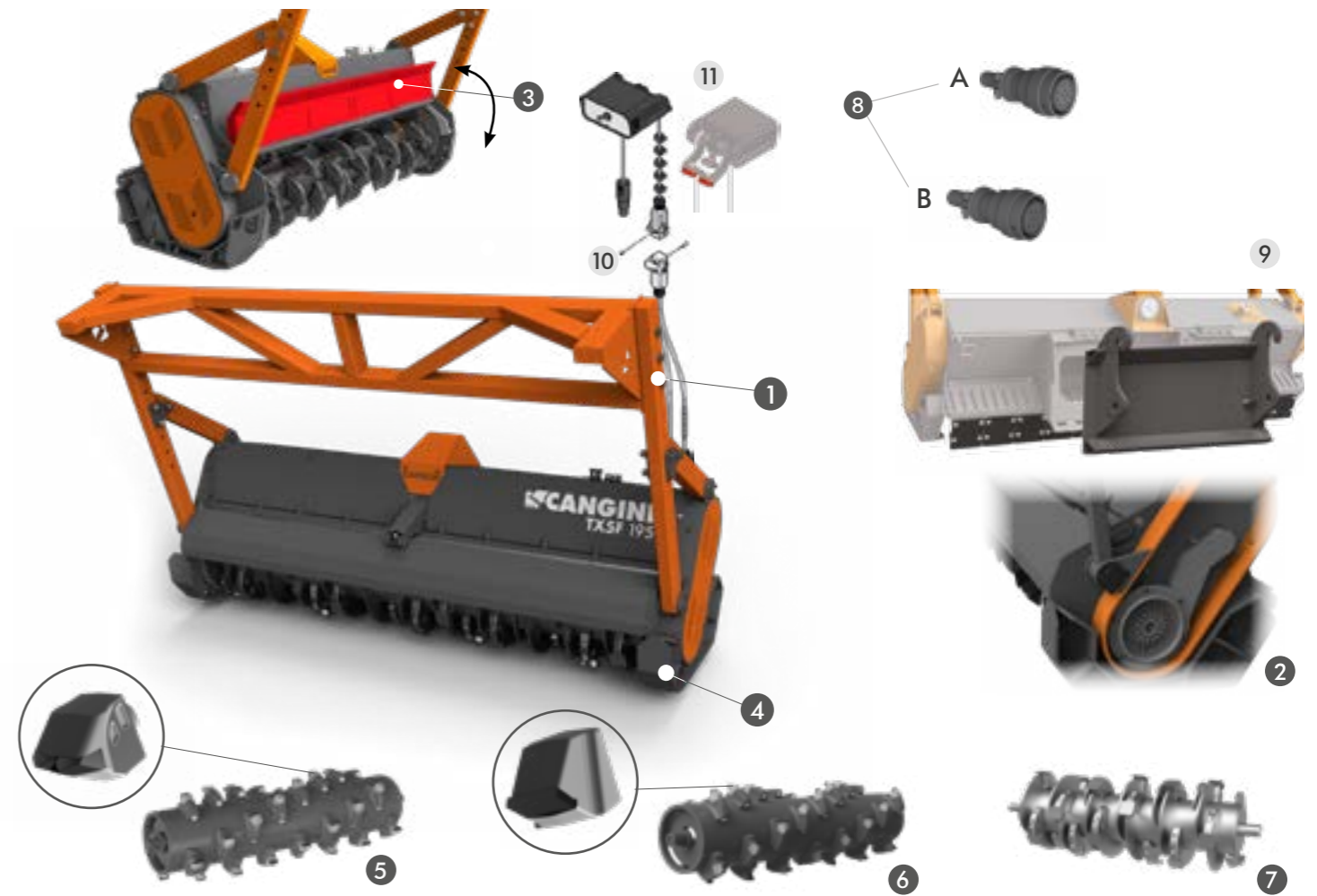

STANDARD TECHNICAL FEATURES

- 1 FRONT PROTECTION FRAME**
THE ADJUSTABLE PROTECTION FRAME ENSURES THAT THE PLANT FALLS AWAY FROM THE OPERATOR.
- 2 AUTOMATIC COOLING SYSTEM**
IT IS EQUIPPED WITH A FORCED-AIR VENTILATION SYSTEM TO HELP REDUCE OVERHEATING OF THE MULCHER'S HYDRAULIC COMPONENTS.
- 3 HYDRAULIC HOOD OPENING**
THE FRONT HOOD OPENING MAKES THE ROTOR PENETRATE THE VEGETATION.
- 4 HB400 REINFORCED SKIDS**
- 5 FORESTRY ROTOR FOR GENERAL USE**
THIS TYPE OF ROTOR IS VERSATILE AND SUITABLE FOR MULTIPLE USES, WITH A HIGH IMPACT RESISTANCE.
- 6 FORESTRY ROTOR CUTTING TOOL**
IS SUITABLE FOR PARTICULARLY HEAVY-DUTY WORK DUE TO ITS AGGRESSIVE PROFILE BUT MORE SENSITIVE TO IMPACTS
- 7 WOOD CHIPS ROTOR**
IT IS HIGHLY VERSATILE AND SUITABLE FOR MULTIPLE USES FROM CUTTING BRUSHWOOD TO TREE GRINDING.
- 8 14 PIN HD36-18-14SE (A) 8 PIN HD36-18-8SE (B) CONNECT**
THE CONNECTOR TYPE YOU REQUIRE MUST BE INDICATED AT THE TIME OF ORDERING. OTHERWISE THE 14-PIN CONNECTOR WILL BE SUPPLIED AS STANDARD.

NB: THE EQUIPMENT IS SUPPLIED COMPLETE WITH PIPES AND CONNECTIONS

OPTIONAL

- 9 ARTICULATED LOADERS HITCH**
IT'S POSSIBLE TO ADD THE HITCH FOR ARTICULATED LOADERS TO THE SKID LOADER HITCH PROVIDED WITH THE STANDARD EQUIPMENT
- 10 2 HOSES KIT**
IT ALLOWS THE FUNCTIONING OF THE HYDRAULIC OPENING/CLOSING OF THE ANTERIOR FLAP ON SINGLE HYDRAULIC LINE MACHINES. CONTROL KIT WITH MAGNETS TO EASILY PUT IT INSIDE THE CAB.
- 11 ELECTRIC KIT**

